

SHACKLE BRUSH

MODEL: EIS-48-1000A

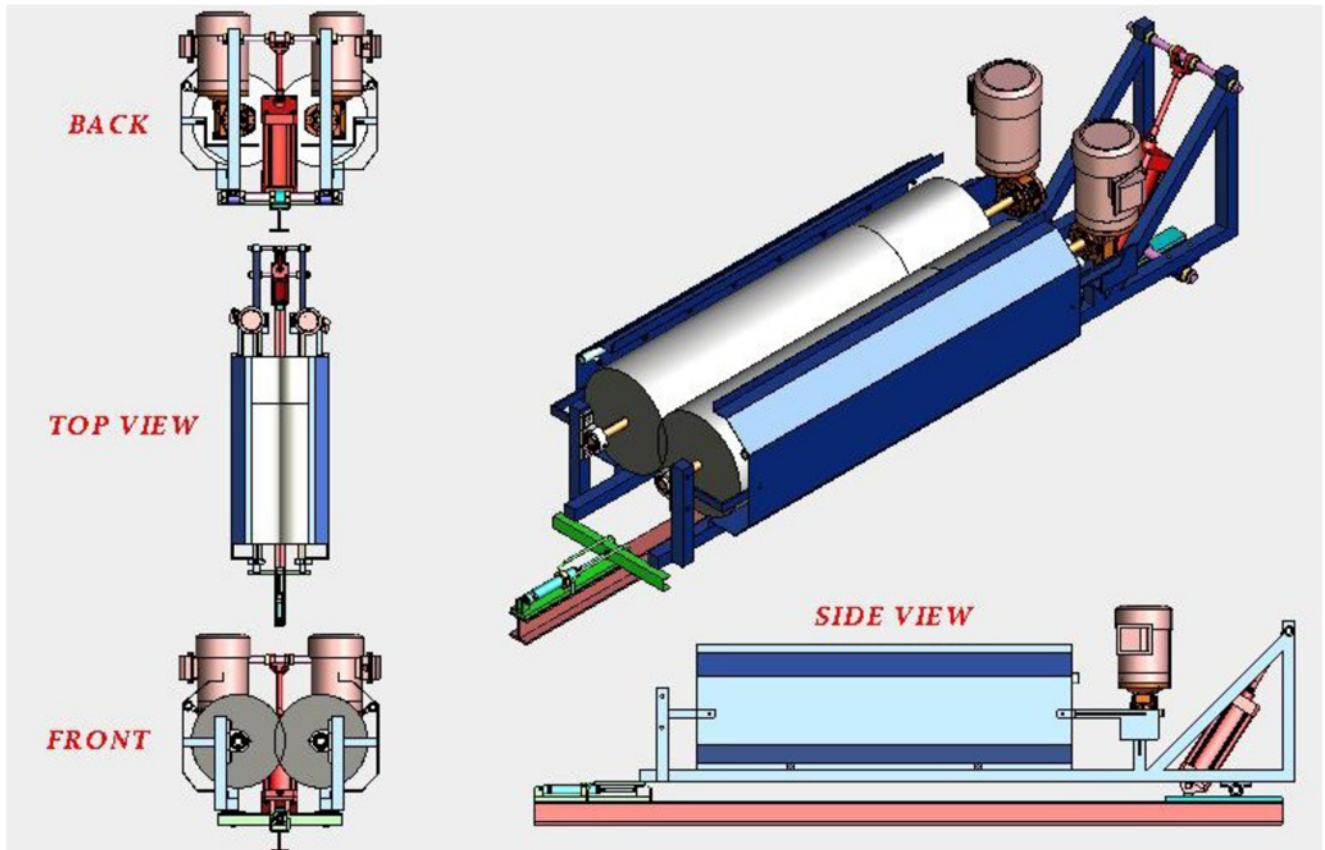

A Member of The Vincit Group



www.vincitgroup.com
saleseis@vincitgroup.com

FEATURES:

- Available Lengths 24", 36", 48" & 60"
- Heavy Duty Air Lift Cylinder
- Air Controlled Safety Bar
- 304 Stainless Steel Heavy Duty Construction
- Stainless Steel 0.5 HP Motor

OPTIONS:

- PLC Controls
- Solenoid Valves and Timers for Rinse/Foam
- Additional Spray Bars and Nozzles
- Turn Key Quotes

SPECIFICATIONS:

- Dimensions: Designed per customer requirements
- Electrical: 230/460 3-Phase 60-Amp
- Air: 90 psi



A Member of The Vincit Group

412 GEORGIA AVE. STE 300 • CHATTANOOGA, TN 37403 • 1-888-484-6248 FAX 423-702-3246